

WATERSIDE TRAINING APTITUDE TEST GUIDANCE

These tests are being used because they are a fair and objective measure of your skills that are considered important for success in this job. The tests allow us to access information that would not be otherwise available from other assessment methods. This test guidance sheet helps give you some hints and tips on taking aptitude tests along with being able to have a go at some of the tests you will be taking so you know what to expect on the test. If you have any questions at all then please contact the office.

WHY DO WE USE TESTS?

- Tests are often used by employers when people apply for jobs.
- The tests help the employer decide if someone has the skills needed to do the job.
- This leaflet is designed to help you prepare for the tests that we use. We will keep your results confidential.
- Should you fail your test, you can request feedback on your test results.

HOW CAN TESTS HELP YOU?

- They will help you to show where your strengths lie.
- They have been chosen because the skills they involve are used in the job.
- The tests are carefully designed so that they are fair to all applicants.
- Taking tests will help you find a job which suits you.

HOW CAN THEY HELP US?

- We get the right sort of people to do the job.
- We find out which jobs might be right for you.
- Tests give us real measures of your strengths and limitations.
- People who do well on the tests usually do well in the job itself.

WHAT SORT OF TESTS WILL YOU HAVE TO DO?

You will undertake a number of tests, which will help us understand your current skill and ability level. The tests that you will take will be;

- Verbal Comprehension
- Spatial Reasoning
- Numerical Reasoning
- Mechanical Comprehension
- Technical Understanding
- Electrical Reasoning
- Colour Blindness

PRACTICE MAKES PERFECT

It will help if you are familiar with the kind of question that will be asked. When you turn over the page you will find several practice questions for each of the skills listed above. The practice tests are not timed but work as quickly and accurately as you can because the real tests do have time limits.

HOW TO DO THE PRACTICE QUESTIONS

Most paper and pencil tests ask you to record your answers on a separate answer sheet so that they can be scored quickly. You should mark your answers to the practice questions by circling your answer you wish to choose on the test paper.

Now see how you get on.

TEST 1 VERBAL COMPREHENSION

For each question choose the correct answer from the five possible answers.
See how many you can do in 3 minutes. Circle your chosen answer below each question.

Choose the word which best completes the following sentences.

1. All employees should _____ from such a training scheme.

A	B	C	D	E
Result	Credit	Succeed	Enrol	Benefit

2. Hard is to soft as hot is to _____

A	B	C	D	E
Cool	Warm	Cold	Icy	Tepid

3. Which of the following words is closest in meaning to toxic?

A	B	C	D	E
Putrid	Poisonous	Bitter	Contagious	Inedible

4. All exposed pipes will have to be _____ to protect them from freezing.

A	B	C	D	E
Insulated	Regulated	Connected	Incorporated	Hot

5. Which of the following words is closest in meaning to vertical?

A	B	C	D	E
Horizontal	Parallel	Straight	Perpendicular	Flat

6. Stay is to leave as advance is to _____

A	B	C	D	E
Arrive	Exit	Retreat	Come	Hold

7. A straight-edge should be used to ensure that the ends of the shelves are correctly _____

A	B	C	D	E
Tightened	Aligned	Concentric	Separated	Flat

8. Adept means the same as;

A	B	C	D	E
Energetic	Inefficient	Enthusiastic	Awkward	Skillful

TEST 2 MECHANICAL COMPREHENSION

Each problem in this test consists of a question which refers to a drawing. Choose the best answer to each question. See how many you can do in 2 minutes.

- 1 With which spanner will it be easier to undo the nut?

If equal, mark C.



- 2 Which shelf will support the heaviest load?

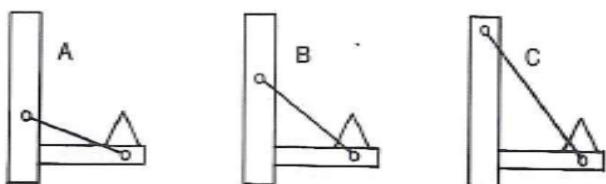

- 3 In which direction can pulley-wheel 'X' turn?

If it cannot turn, Mark C

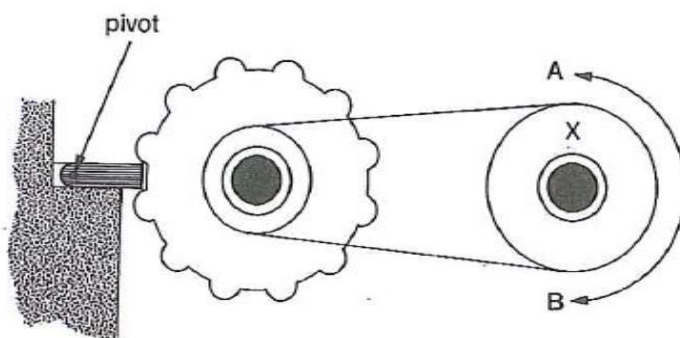

- 4 Which way will the pointer move when the shaft turns in the direction of the arrow?
If neither, Mark C.

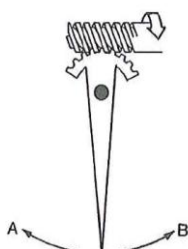

TEST 3 TECHNICAL UNDERSTANDING

Your task is to read each passage carefully; then, using the information provided, answer the questions which follow. See how many you can do in 2 minutes.

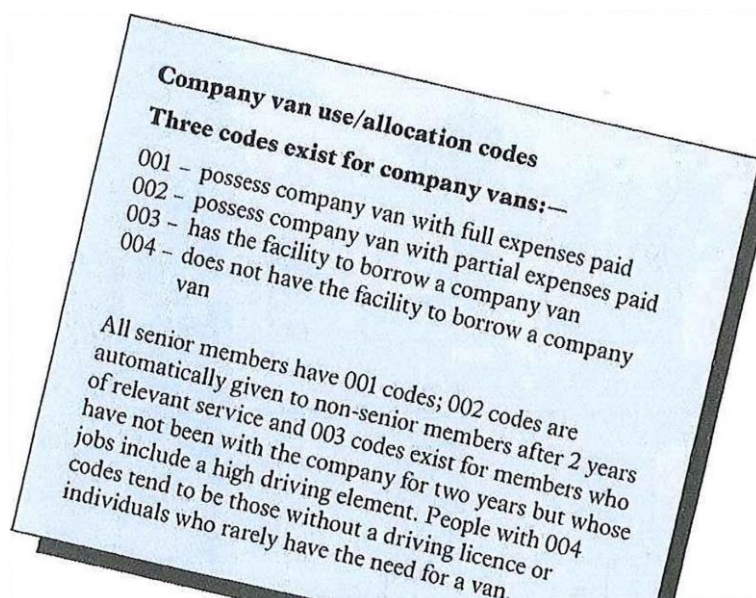

- 1 Which code would a senior member with two years service have?
 - A) 001.
 - B) 002.
 - C) 003.
 - D) 004.

- 2 Members who only have 1 year of service but spend a large part of their time driving, would have which code?
 - A) 001.
 - B) 002.
 - C) 003.
 - D) 004.

- 3 Which facility is unique to code 002?
 - A) The company van.
 - B) Partial expenses.
 - C) Full expenses
 - D) A borrowing facility.

- 4 An individual who has worked for the company for three years but who does not drive would be given what code?
 - A) 001.
 - B) 002.
 - C) 003.
 - D) 004.

TEST 4 NUMERICAL REASONING

In this test, you are given numerical problems to solve. Choose the correct answer from five possible answers given. See how many you can do in 3 minutes using a calculator.

1. If 1,000 ball bearings cost £42.50, how much would 2,300 cost?				
A £85	B £97.75	C £105.50	D £110.25	E £125.50

2. How many rivets are needed to attach a 10cm brass plate if one rivet is inserted every 4mm (10mm = 1cm)?				
A 5	B 15	C 25	D 250	E 500

3. When totally full, a barrel contains 75 litres of oil. How many litres of oil remain if 40% has been used?				
A 1.25 litres	B 30 litres	C 45 litres	D 60 litres	E 75 litres



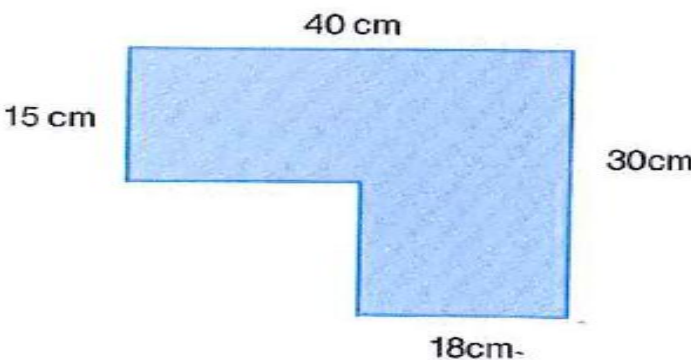





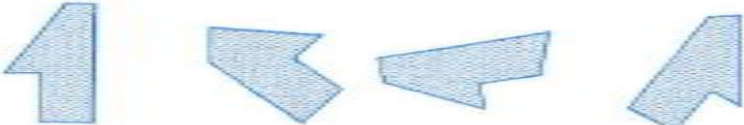
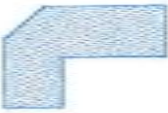

4. A press stamps out 5 components every minute. How many components would be cut out in 8 hours if the same rate was maintained?				
A 96	B 300	C 600	D 2,400	E 5,760

5. What is the area of the steel plate shown below?				
				
A 870 sq cm	B 880 sq cm	C 890 sq cm	D 900 sq cm	E 910 sq cm

6. A piece of timber has been cut into two lengths in the ratio of 7:2. If the original piece of timber was 828 cm long, how long is the larger of the cut lengths?				
A 118 cm	B 184 cm	C 591 cm	D 600 cm	E 644 cm

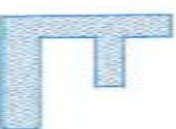
TEST 5 SPATIAL RECOGNITION

In this test, you are to choose the shape on the right which is identical to the give shape. The identical shape may be rotated on the page, but not turned over. See how many you can do in 2 minutes.

<p>1</p> 	 <p>A B C D</p>
<p>2</p> 	 <p>A B C D</p>
<p>3</p> 	 <p>A B C D</p>
<p>4</p> 	 <p>A B C D</p>
<p>5</p> 	 <p>A B C D</p>
<p>6</p> 	 <p>A B C D</p>

TEST 6 ELECTRICAL REASONING

In this test, you will be given 4 sets of electrical information, including circuits, formulas and relationships. There are 5 questions based on each set of information.

Example Set

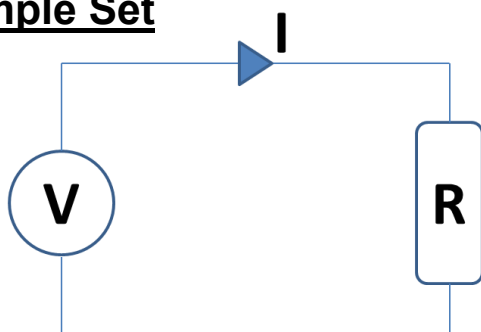

In a circuit, a voltage source **V** will push a current **I** through a resistor **R** based on the following relationship:

$$V = I \times R$$

1. If $I=7$ and $R=3$, what is the value of V ?
 - a. 10
 - b. 4
 - c. 21
 - d. -4

2. If $I=4$ and $V=4$, what is the value of R ?
 - a. 1
 - b. 0
 - c. 2
 - d. 4

3. If $R=6$ and $V=3$, what is the value of I ?
 - a. 3
 - b. 0.5
 - c. 9
 - d. 18

COLOUR BLINDNESS

This test uses coloured plates to test the type and seriousness of colour vision deficiencies, which looks at the range of colour blindness. This is essential where you are working with electricity and or colour related roles and industries. identify the correct number, or correctly trace the wiggly lines.

Look at the images from an approximately 75cm distance.

Preferably have mild natural light and no glare. Interior lights and glare can alter the color of the pictures.

Attempt to identify the hidden number or line within 5 seconds

Write the number below the circle, if you see no line or number put an x below the circle or draw the image within the circle of what you see within the circles given below.

ISHIHARA COLOR BLINDNESS TEST PLATE 1

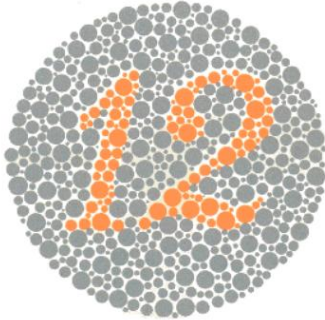

ISHIHARA COLOR BLINDNESS TEST PLATE 2

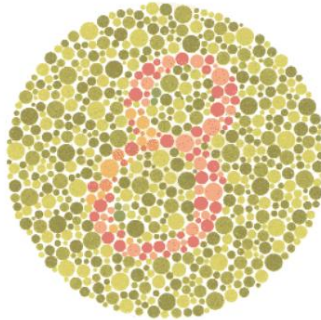

ISHIHARA COLOR BLINDNESS TEST PLATE 4

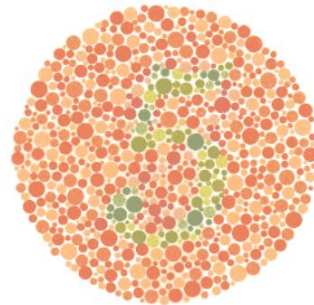

ISHIHARA COLOR BLINDNESS TEST PLATE 15

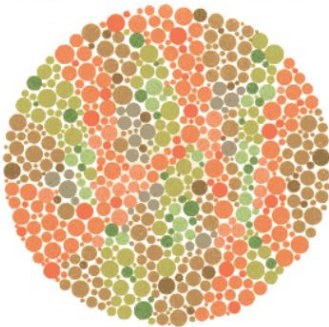

ISHIHARA COLOR BLINDNESS TEST PLATE 17

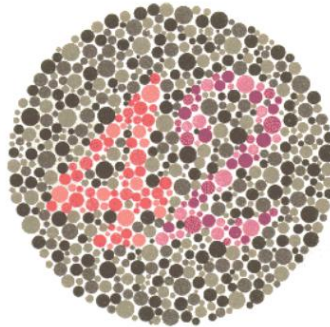

ISHIHARA COLOR BLINDNESS TEST PLATE 20

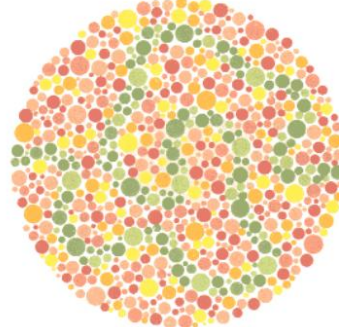

ISHIHARA COLOR BLINDNESS TEST PLATE 24

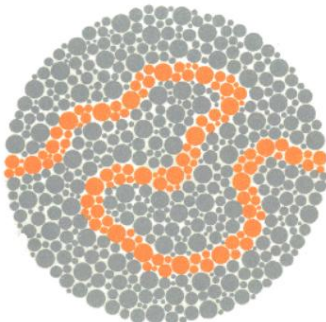

ISHIHARA COLOR BLINDNESS TEST PLATE 22

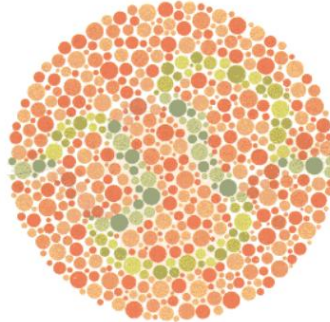

ISHIHARA COLOR BLINDNESS TEST PLATE 23

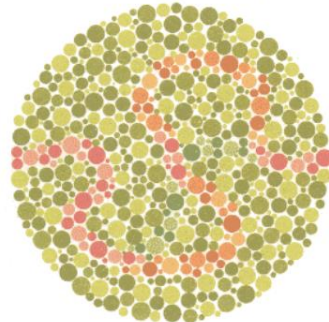

ANSWERS TO PRACTICE QUESTIONS

TEST 1 VERBAL REASONING	<ol style="list-style-type: none"> 1. E 2. C 3. B 4. A 5. D 6. C 7. B 8. E
TEST 2 MECHANICAL COMPREHENSION	<ol style="list-style-type: none"> 1. A 2. C 3. B 4. B
TEST 3 TECHNICAL UNDERSTANDING	<ol style="list-style-type: none"> 1. A 2. C 3. B 4. D
TEST 4 NUMERICAL REASONING	<ol style="list-style-type: none"> 1. B 2. C 3. C 4. D 5. A 6. E
TEST 5 SPATIAL REASONING	<ol style="list-style-type: none"> 1. A 2. C 3. D 4. B 5. D 6. C
TEST 6 ELECTRICAL REASONING	<ol style="list-style-type: none"> 1. C 2. A 3. B
COLOUR BLINDNESS	<ol style="list-style-type: none"> 1. 12 2. 8 3. 5 4. X = No number or wiggly line 5. 42 6. Wiggly Line 7. Wiggly Line 8. Wiggly Line 9. Wiggly Line

WHAT CAN YOU DO TO GIVE YOUR BEST PERFORMANCE

Don't be down-hearted if you found the questions difficult or got a lot of them wrong. There are many things you can do to improve your performance.

On verbal tests

Read books and newspapers. Do verbal puzzles and crosswords. Play word games.

On numerical tests

Practice doing simple arithmetic with or without a calculator. Do number puzzles. Do the scoring when playing games such as darts, card games etc.

On mechanical tests

Try and understand how household appliances work. Repair mechanical things. Build working models. Understand what Mechanical Principles mean and how gears work.

On spatial tests

Draw plans, do jigsaw puzzles, make up patterns. Assemble construction sets.

On electrical tests

Try and understand how plugs work. What would you find inside a plug, wire, components, understand how a plug is wired and how electricity flows. What is Ohm's Law and Electrical Principles. Look at understanding and learning some electrical formulas and what are fuse ratings.

Finally - be prepared for the testing session.

Make sure you read the question properly, what is it asking you to do?

Before the session

Don't stay up all night.

Give yourself plenty of time to get to the session so you don't have to rush.

If you wear glasses or a hearing aid, be sure to take them with you.

If you have a disability which might make taking the test difficult for you, let us know in advance so we can make appropriate arrangements. If you require one to one testing you will need to provide the appropriate paperwork and or report exempting you from group testing conditions.

At the session

Listen carefully to instructions.

Do exactly as you are told.

Don't be afraid to ask questions.

Read each question carefully before answering.

Work quickly and accurately, as most tests have short time limits and many questions.

Don't waste time on difficult questions.

Try as hard as you can. The more questions you get right the higher your score will be.

GOOD LUCK !

